

Class 'B', 'C' or 'D' 900 x 600
Clear Opening Grate & Frame
Bikesafe, Galvansied and bolt
down as per AS3996:2019

PLAN

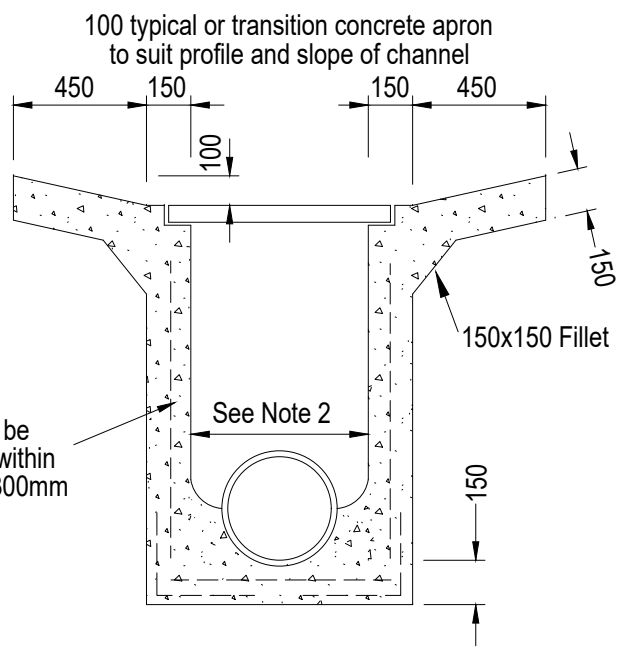

Reinforcement to be centrally located within wall. Laps to be 300mm min. See Note 3.

SECTION A-A

NOTES

1. For depth of invert greater than 1.5m, min. wall & base thickness to be 200mm, and base to be corbelled out to 900 x 900mm.
2. Min. internal pit dimension = external pipe dia. + 150mm. For pipe dia. greater than 450mm corbel pit top to a min. of 600mm.
3. SL82 reinforcing is required for pits greater than 1200 depth.
4. Concrete strength shall be 25MPa at 28 days.
5. Precast pits only as approved



SCALE: 1 :25	DATE: Dec 2012
DRAWN: S.R./P.J.D.	CHECKED:

APPROVED: *Addy*
MANAGER ENGINEERING SERVICES

GRATED CATCH PIT

LAST AMENDED: May 2022
SD 235
PAGE 1 OF 1