

NOTES:

1. All timber to be of first quality fine-sawn Cypress Pine or similar approved; sanded, not dressed; straight grained, free of splits, gum veins or splinters & treated with Cabots Natural Decking Oil prior to installation. All exposed edges to have a 10mm bull nose & be sanded smooth.
2. Fixing generally to be 100mm x 14g galvanised counter sunk head screws unless otherwise shown. (Screws shorter where necessary). Slats to be fixed to members using 2 screws per connection.
3. All metal fittings and connectors to be Galvanised. All nuts & bolts to be tamper resistant.
4. Table to be mounted in a 3000 x 2400 x 100 FCR pad with 100 x 75 treated pine surround. When directed, FCR pad to be replaced with 3000 x 2400 x 100 concrete pad with reinforcement SL62 steel mesh placed on 40mm bar chairs.

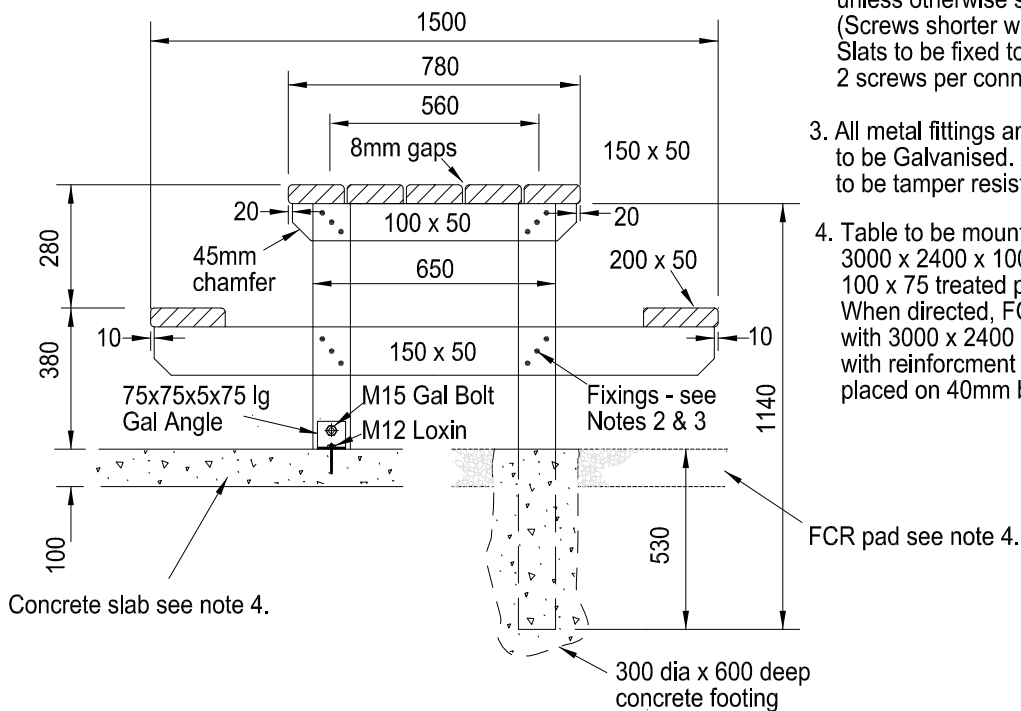

SCALE: N.T.S.

DATE: Dec 2012

APPROVED:

DRAWN: P.J.D.

CHECKED: DS

INFRASTRUCTURE MANAGER

LAST AMENDED: June 2013

PICNIC TABLE

SD 700

PAGE 1 OF 1