

NOTES:

1. All concrete 25 mpa
2. Pitch 20120 x 1800 x 100 deep concrete slab with F62 mesh
3. Pitch surrounds, run up etc 100 depth unreinforced concrete slab. Fence to be installed prior to pouring.
4. Concrete surface to be 'wood float' finish except for 'transverse broom finish' to run up.
5. End & Corner posts - DN80 Medium Grade set in concrete footings 300 dia x 900 deep
6. Intermediate posts (3000 centres)- DN40 medium grade set in concrete footings 250 dia x 750 deep
6. Top & bottom rails to 3 sides - DN40 medium grade.
7. Roof rails - DN40 medium grade.
8. Provide 2 rows of Helicoil Cable to fence.
9. Chain-link Mesh to sides & roof (Heavy Duty Fabric) - 3000 high to 4500 to hip 50 pitch x 3.15mm Black PVC coated wire.
9. Chain-link Mesh to rear only (Extra Heavy Duty Fabric) - 3000 high 40 pitch x 3.15mm Black PVC coated wire.
10. All Mesh strained taut & fully laced to perimeter with 2.0 mm black PVC coated wire.
11. All pipework & fittings to be powder coated Black.
12. Synthetic surfacing to be of an approved type.

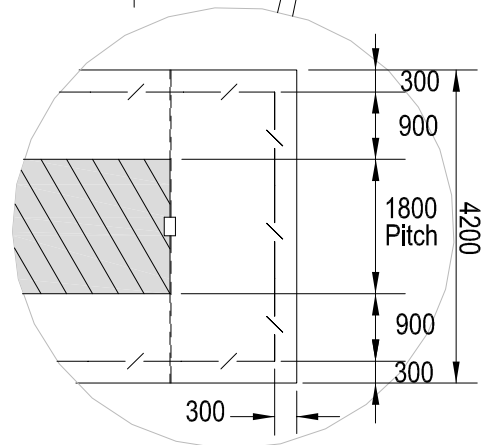

SCALE: 1 : 200

DATE: Dec 2012

APPROVED:

DRAWN: P.J.D.

CHECKED: DS

INFRASTRUCTURE MANAGER

LAST AMENDED:

June 2013

**CRICKET PRACTICE
WICKET**

SD 701

PAGE 1 OF 1